

N.Y.S.M.A.

NEW YORK STATE MICROD ASSOCIATION

PRINT DATE: FEBUARY 12, 2000

Chapter 6 - Classic Microd Division Plan Book

Section 1.0 Introduction

Classic Microds are cars that are raced today which are based on the "CLASSIC" 1967 New York State Microd Association plan book design. At the time, these cars were called "Specials" and were a revolutionary design - compared to the original Microd design. The main difference with the newer car was that the axles were above the frame, rather than below. This allowed a lower center of gravity and better stability, especially in the turns. The design resulted in a safer car that was easy to build and maintain.

When the Finger Lakes Microd Club was formed in the mid-80's, they adopted a plan book that had little change from the 1967 N.Y.S.M.A. Plan Book. After several years, the class names were officially changed to include the description "CLASSIC". Finger Lakes Microd Club is no longer a NYSMA member club, but the classes and cars continue to race as a part of the Cortland County Microd Club.

This Plan Book is the first to be published using the "CLASSIC MICROD" designation. Though the order of assembly has been changed and a few of the drawings have been updated, the design and specifications are unchanged from the 1967 design.

Sure, technology has moved on and there are different and maybe even better ways to build a Microd. But there is a unique satisfaction in building and racing a "CLASSIC".

DISCLAIMER:

BUILDING FROM THESE PLANS IS DONE AT THE RISK OF THE BUILDER. NO RESPONSIBILITY FOR SAFETY, PERFORMANCE OR RELIABILITY WILL BE ASSUMED BY NYSMA. ADDITIONAL MATERIALS NOT LISTED MAY BE OBTAINED AS NEEDED. REFER TO THE DRAWINGS FOR SPECIFICATIONS. AT NO TIME SHOULD YOU REDUCE THE MARGIN OF SAFETY!!

Section 2.0 General Information

.1 NUMBERS:

- .1 All cars must have 6" car numbers on the hood and on both left and right side body panels.
- .2 Car numbers on the side body panels must appear to the rear of the back roll cage upright.
- .3 All cars must have numbers a minimum of 3 1/2" in height on the seat back or gas tank.
- .4 Car numbers must be of a type and color which offers good contrast and is easily discernible by the Scorers.
- .5 The club letter must appear to the right of the car number on the hood, and on the left and right side body panels. The letter must be a minimum of 3" and a maximum of 4" in height. Club letters are listed below.
- .6 You may choose any valid unused number from the club list. Once you have raced with a number, you must obtain approval from the Board of Directors to change it.

.2 CLUB LETTERS: Classic Microd Club....."C"

.3 TIRES: For the reason of low cost and standardization of equipment, the following brands of tires and widths are allowed.

- .1 CLASS: Novice Classic... 11 x 3.5 x 5
MR1 Classic.....11 x 3.5 x 5 Cheng Shin and or Carlisle tires only.
MR2 Classic.....11 x 4.5 x 5
- .2 Tire additive or Tire softeners are **NOT** permitted, and are grounds for disqualification.

.4 AGE REQUIREMENTS:

- .1 Novice Classic:
Fifth birthday thru 10 years old.*
- .2 MR1 Classic:
11 years old thru 14 years old.*
 - .1 A driver 9 years old with 2 years racing experience may race in this class.
 - .2 A driver 10 years old with 1 year racing experience may race in this class.
- .3 MR2 Classic:
14 years old thru the end of enrollment in High School.*
 - .1 A driver 12 years old with 2 years racing experience may race in this class.
 - .2 A driver 13 years old with 1 year racing experience may race in this class.

* Ages are as of July 15th.

.5 WEIGHT:

- .1 Novice Classic 325 lb.
- .2 MR1 Classic 375 lb.
- .3 MR2 Classic 375 lb.

.6 GEAR RATIOS:

- .1 Novice Classic 5.83 : 1
- .2 MR1 Classic 5.83 : 1
- .3 MR2 Classic 4.83 : 1

.7 ENGINES:

- .1 All Engines used in these classes are provided by the participating Clubs.
- .2 All Engines are built the same for this class.
- .3 All Engines are marked by a number or letter and are drawn randomly on a weekly basis for competition.
- .4 All tech inspections of these engines is done at the Club's discretion.

Section 3.0 Construction Materials

Section 3.1 Lumber

IT IS IMPORTANT TO CUT AND MARK ALL PIECES BEFORE STARTING ASSEMBLY.

<u>Quantity</u>	<u>Size</u>	<u>Description</u>	<u>Part Number</u>
Hardwood:			
(2)	3/4 x 4 x 7'	Scrub Rails	(23) (24)
		Front Bumper	(25)
Plywood:			
(1)	4' x 8' x 3/4	- can be cut to make the following:	
	36 x 48	Front Bed	(1)
	11 x 32 3/4	Front Grill	(2)
	6 x 36	Rear Bumper	(3)
	8 5/8 x 24	Rear Engine Bed	(4)
	10 1/2 x 24	Front Engine Bed	(5)
	12 x 36	Seat Bottom	(6)
	? x 36	Seat Back	(7)
	9 1/2 x 14	Seat Divider	(8)
	12x 36	Seat Trim	(11)
(2)	1 5/8 x 6	Rear Cross Frame Spacer	(13)
(2)	1 5/8 x 7	Rear Engine Bed Spacer	(14)
(2)	1 5/8 x 10 1/2	Front Engine Bed Spacer	(15)
(2)	4' x 8' x 3/8 or 1/4 or Louan	- can be cut to make the following:	
(2)	15 1/2 x 28 1/2	Front Fender	(16)
(2)	7 x 18	Rear Fender	(18)
(2)	8 x 14	Dash Cover	(19)
(2)	15 3/4 x 6' 10 1/4	Sides	(20) (21)
	36 1/4 x 36 3/4	Hood	(22)
Dimensional Softwood: (many dimensions assume that the 2 x 2 is a 2 x 4 ripped in half - not a true 2 x 2)			
(2)	1 x 1 1/2 x 30	Side Hood Anchors	(26)
(1)	2 x 4 x 32	Front Cross Frame	(A)
(2)	2 x 2 x 6' 6"	Left and Right Frame *	(B) (C)
(3)	x 36	Dash Top	(D)
		Top Rear Cross Frame	(I)
		Bottom Rear Cross Frame	(J)
(1)	x 32	Top Grill Support	(P)
(2)	x 19 1/2	Left / Right Axle Hanger	(N) (O)
(2)	x 15	Left / Right Dash Side	(E) (F)
(2)	x 13	Left / Right Seat Uprights	(K) (L)
(2)	x 10	Seat Upright / Block	(T) (U)
(2)	x 8 1/4	Left / Right - Bottom	(G) (H)
(7)	x 6	Axle Blocks (4)	(M)
		Left / Right Grill Support	(Q) (R)
		King Pin Spacer	(S)

* These pieces may be hardwood at builder's option.

Section 3.2 Hardware

Wood Screws:

50 - 1 1/4" - #9 Flat Head
25 - 1 1/2" - #9 Flat Head

Washers:

1 lb. - 1/4" Flat
50 - 1/4" Lock

Hex Nuts:

150 - 1/4"

Steel:

4 - 1/8 x 1 x 2" Flat
2 - 1/8 x 1 x 6" Flat
2 - 1/8 x 1 x 18" Flat
2 - 1/8 x 3/4 x 13" Angle
1 - 1/8 x 3/4 x 17" Angle
1 - 3/16 x 1 x 2" Flat
1 - 1/4 x 1 x 6" Flat
2 - 1/4 x 1 1/2 x 7" Flat
1 - 1/4 x 4 1/2 x 13" Plate
2 - 1/4 x 1 x 4 1/2" Flat
1 - 1/8 x 1 x 24" Square Tube
1 - 1/8 x 1 x 28" Square Tube
1 - 5/8 x 18" Cold Rolled Round

Carriage Bolts:

12 - 1/4 x 2"
24 - 1/4 x 2 1/2"
24 - 1/4 x 3"
30 - 1/4 x 3 1/2"
2 - 1/4 x 4"
10 - 1/4 x 4 1/2"
10 - 1/4 x 6 1/2"

Machine Bolts:

4 - 3/4 x 10
3 - 3/8 x 5 1/2"
2 - 1/4 x 5 1/2"
4 - 1/4 x 2"
1 - 5/16 x 1 1/2"
2 - 3/8 x 2"

Pulleys:

2 - 3/8 x 2 or 2 1/2"
2 - 5/8 x 5 or 5 1/2"

E. M. T. :

5 - 3/4" O. D. x 10'

Misc:

1 - 5/8 x 2" I. D. Steel Bushing
2 - 5/8" I. D. Bearings and Hangers
2 - Small Cable Thimbles and Clamps
1 - 1/4" Turn Buckle
4 - 1/4 x 1 1/2" Wall Anchors
4 - 1/4 x 3/4" Wall Anchors

Section 3.3 Misc. Parts

These parts listed below can be obtained through American Power Sports or most any other go-kart or mini-bike dealer.

2 - Mini bike/Go kart Brake w/1" axle hole.
2 - 4 1/2" Brake Drum - 1 w/sprocket flange.
1 - Sprocket - 58 tooth/MR2 70 tooth/ MR1 and Novice.
1 - Steering wheel - 10 to 13" allowed.
1 - Steering Shaft and Hub - 5/8".
4 - 5" All Aluminum Wheels, complete with 3/4" Roller Bearings.
5 - 3/4" - 16 Axle Nuts (lock-nuts).
1 - 3' #35 E K Space Chain.
3 - Master links.
1 - Chain Breaker.

NOTE: These lists do not include material for the throttle and brake pedal assemblies and linkage, nor do they include material for the fuel tank, fuel filter or fuel hose.

Section 4.0 Construction Sequence

To prevent wasted time and backtracking during assembly, the following sequence should be used.

- .1 **FRAME:**
 - .1 Nail Rear Cross Frame Spacers (13) to bottom of Top Rear Cross Frame (I) at ends.
 - .2 Bolt Rear Engine Bed (4) between Top Rear Cross Frame (I) and Bottom Rear Cross Frame (J) so that the back of Rear Engine Bed (4) is flush with back of Top Rear Cross Frame and Bottom Rear Cross Frame (J).
 - .3 Nail Rear Engine Bed Spacer (14) to top of rear ends of Left Frame (B) and Right Frame (C).
 - .4 Measure 14" from back of Front Bed (1) and draw line across.
 - .5 Measure 1 5/8" from front of Front Bed (1) and draw line across.
 - .6 Center Left Frame (B) and Right Frame (C) on Front Bed (1) so that the outside of the front ends are 16" apart and touching line drawn in step 5.
 - .7 Place Rear Engine Bed (4) over Rear Engine Bed Spacers (14) so that frame ends are tight against Bottom Rear Cross Frame (J) and 24" apart. Clamp securely.
Caution: Before proceeding, use a straight edge to be sure outside edges of Front Bed (1) line up perfectly with ends of Top Rear Cross Frame (I) and Bottom Rear Cross Frame (J).
 - .8 Bolt Left Frame (B) and Right Frame (C) to Front Bed (1) and Rear Engine Bed (4). Bolt only where shown.
 - .9 Saw on line of Front Bed (1) marked in step 4 from each edge to frame.
 - .10 Saw Front Bed (1) from front along outside of Left Frame (B) and Right Frame (C) to previous cut in step 9. Remove corner pieces.
 - .11 Trim outside ends of Rear Engine Bed (4) along sides of Left Frame (B) and Right Frame (C).
 - .12 Center Front Cross Frame (A) on Front Bed (1) tight against ends of Left Frame (B) and Right Frame (C) and bolt center and right side. (Do not bolt left side.)
 - .13 Bolt Rear Bumper (3) on the back of Top Rear Cross Frame (I) and Top Rear Cross Frame (J).(Stagger Bolts.)
- .2 **DASH:**
 - .1 Cut and fit Right Dash Bottom (H), Left Dash Bottom (G), Right Dash Side (F), Dash Top (D) and Left Dash Side (E) corner joints as shown in insert.
 - .2 Bolt Left Dash Bottom (G) and Right Dash Bottom (H) on Front Bed (1) at sawed edges.
 - .3 Assemble dash by bolting corners. Keep square.
 - .4 Clamp Dash Covers (19 - 2 pieces) on front of dash. (Dotted lines on drawing.) Cut corners of Dash Covers (19) to mess corner bolts of dash.
 - .5 Screw Dash Cover (19) to dash with flat head wood screws.

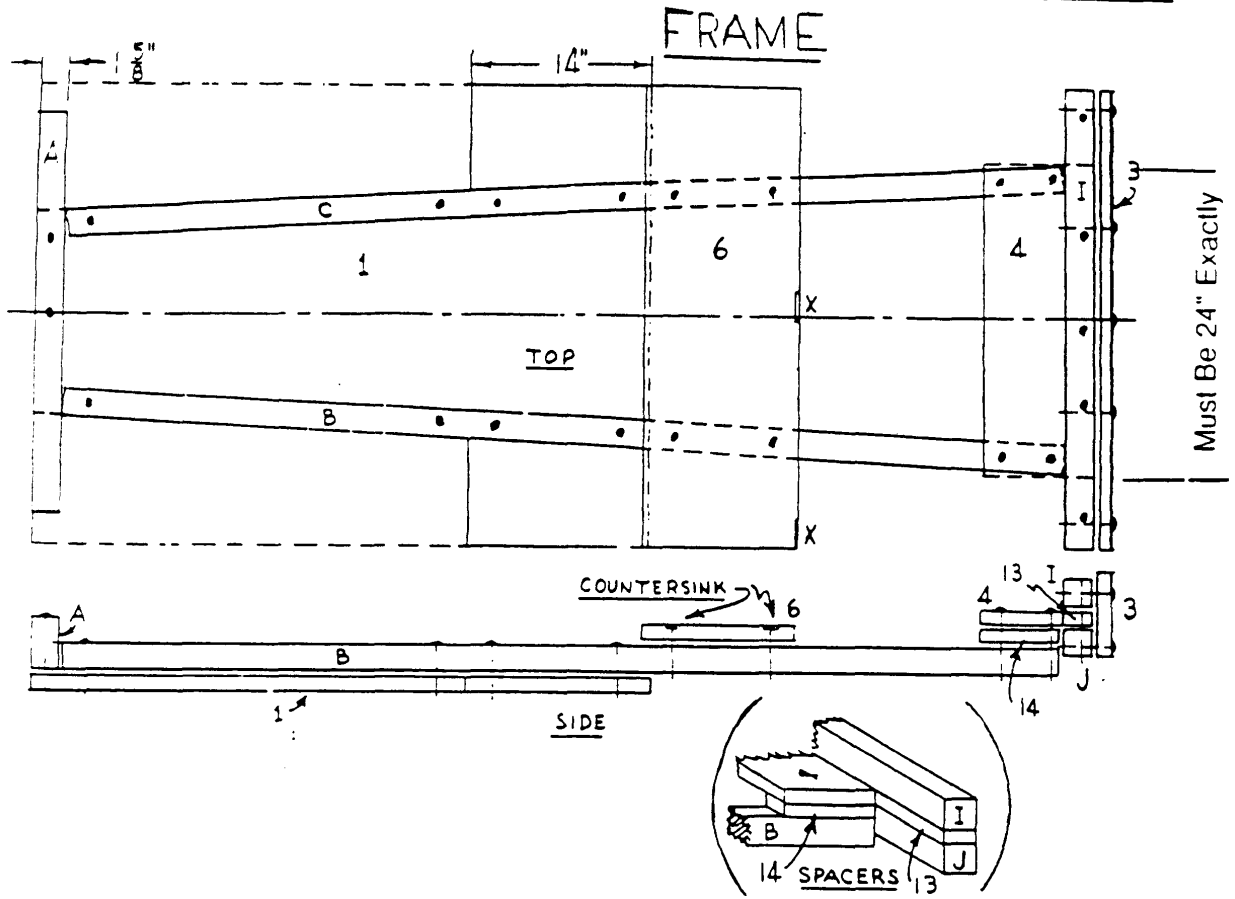

DASH

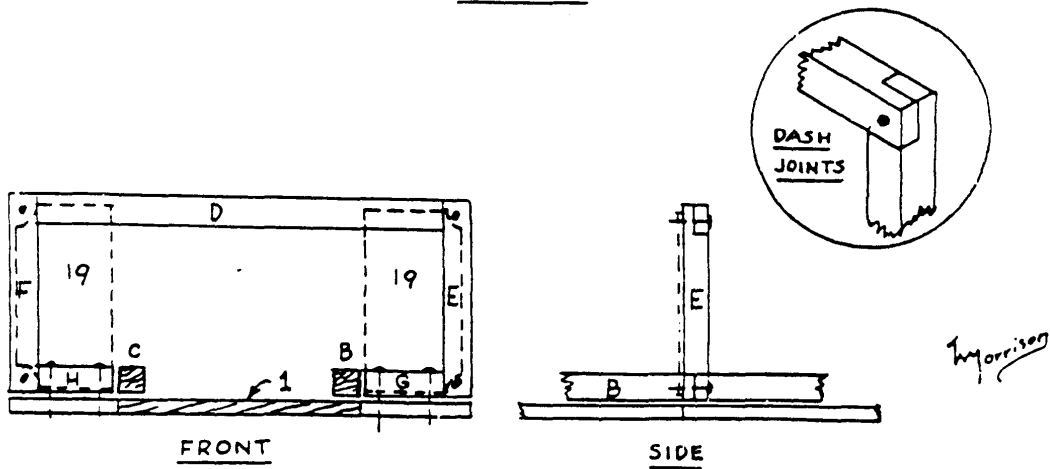

Section 4.0 Construction Sequence (con't.)

.3 AXLES:

Purchased axles are allowed., but good, rugged axles may be made according to the drawings. Be sure tubing has a full 1/8" thick wall. If drive wheel to be used has a sprocket flange, allow proper space on the axle. When properly assembled, the wheelbase must be 54 1/2" plus or minus 1".

- .1 Axle materials are 1/8" x 1" square steel tubing and 3/4" x 10" bolts. Bolt heads are removed and bolts are inserted into ends of steel tubing to create axle.
- .2 Allow 1/4" for welding tubing to bolt.
- .3 Allow space for grease seal bushing if Timken bearing wheels are used.
- .4 Drill center of front axle with a 3/8" hole for kingpin.
- .5 Front axle should have welded reinforcement at center to prevent breaking at the king pin hole.

.4 KING PIN:

- .1 Cut and drill 3 pieces of band iron and King Pin Spacer (S) as shown.
- .2 Measure center of Front Bed (1) and locate king pin center 17 3/8" from front of Front Bed (1).
- .3 Make 3 spacers of 3/8" pipe.
- .4 Assemble and bolt to Front Bed (1) but leave out king pin and short spacer.
- .5 Insert front axle.
- .6 Insert king pin with short spacer fitted under axle so that axle turns freely. Use double nuts on king pin.

.5 FRONT AXLE FRAME:

- .1 Drill and countersink iron pieces shown on drawing.
- .2 Center iron on Left Axle Hanger (N) and Right Axle Hanger (O) and fasten as shown. (If heads of screws protrude, file smooth.)
- .3 Place wheels on front axle.
- .4 Rotate axle and adjust Rear Axle Blocks (M) to stop tires from hitting Left Frame (B) and Right Frame (C) by at least 1".
- .5 Clamp and drill through Left Axle Hanger (N), Axle Blocks (M), Left Frame (B), and Front Bed (1).
- .6 Bolt each side as shown. Bolts should extend at least 1/2".

.6 DASH BRACE:

- .1 Cut pipe and flatten ends to fit as shown.
- .2 Drill braces and bolt to Dash Top (D) and Left Axle Hanger (N), Right Axle Hanger (O).

AXLES

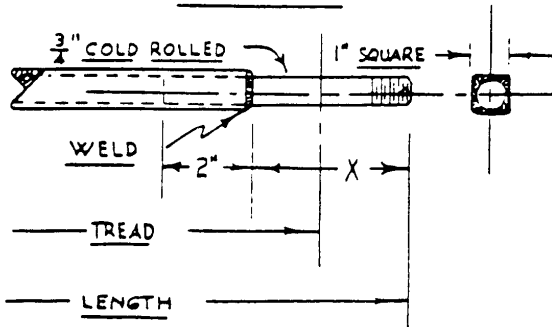

X - DEPENDS ON WHEEL TYPE - ALLOW FOR
 GREASE-SEAL BUSHING AND NUT
 TREAD - FRONT: $28\frac{1}{2}$ " REAR: $31\frac{1}{2}$ "

FRONT

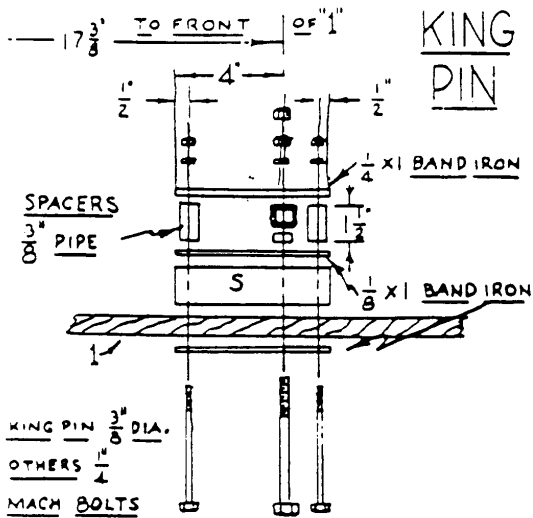
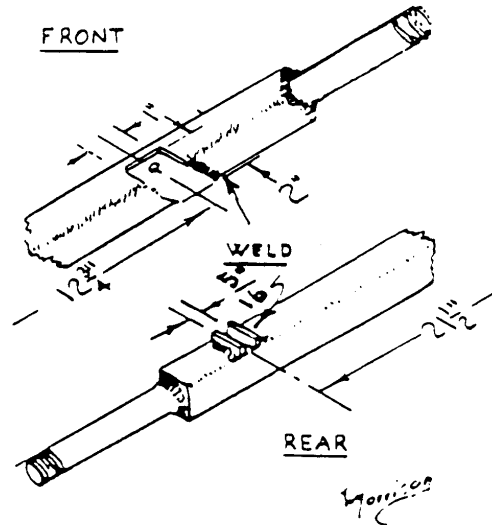

DASH BRACE

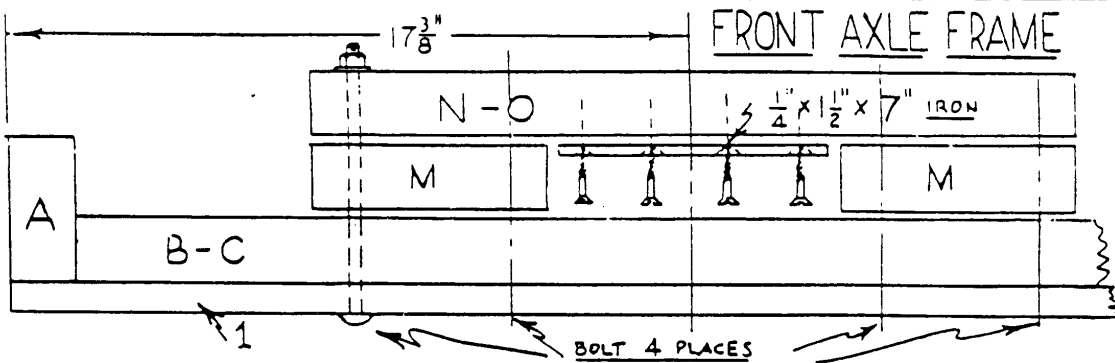
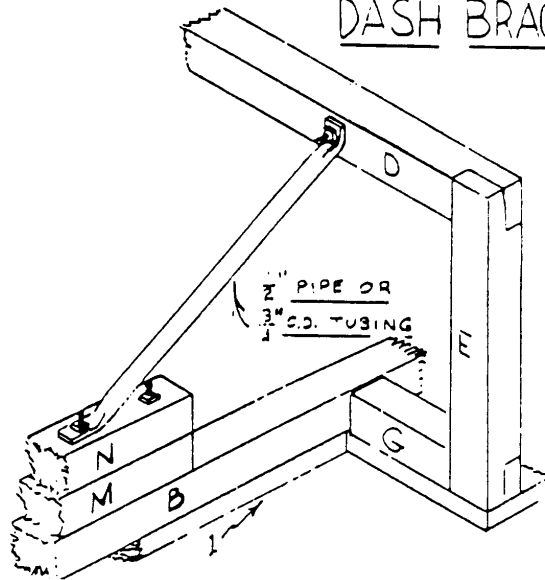

Section 4.0 Construction Sequence (con't.)

- .7 STEERING PULLEYS**
- .1 Drill 3/8" holes at ends of Front Cross Frame (A) as shown.
 - .2 Countersink so 3/8" machine bolt heads will be exactly flush with front of Front Cross Frame (A).
 - .3 Assemble spacers, washers and pulleys. Turn on first nut to allow pulley to turn freely.
 - .4 Bend band iron to form brace for pulley bolts.
 - .5 Drill and assemble brace to Front Cross Frame (A). Bolt on with 1/4" carriage bolts. (Heads must be countersunk into Front Cross Frame (A).)
 - .6 Tighten second nut to lock brace in position. (Check to make certain pulley still turns freely.)
- .8 FRONT GRILL**
- .1 Mitre corners of Top Grill Support (P), Left Grill Support (Q), and Right Grill Support (R) to fit 3/8" from top and edges of Front Grill (2).
 - .2 Bolt Top Grill Support (P), Left Grill Support (Q), and Right Grill Support (R), to Front Grill (2). Use only one bolt at top of Left Grill Support (Q) and Right Grill Support (R).
 - .3 Bolt Front Grill (2) to Front Cross Frame (A) so that bottom of Front Grill (2) is flush with bottom of Front Bed (1). (Use four bolts.)
- .9 FRONT BRACES**
- .1 Cut 2 pieces of 3/4" tubing to fit as shown.
 - .2 Flatten ends of tubing.
 - .3 Drill tubing to fit and bolt to Top Grill Support (P) and Left Axle Hanger (N), Right Axle Hanger (M).
- .10 STEERING ASSEMBLY**
- .1 Bolt through Front Bed (1), Front Cross Frame (A), and Front Bearing Holder to anchor Front Column Bearing.
 - .2 Bolt through Dash Top (D) and Rear Bearing Holder to anchor Rear Column Bearing. Countersink bolt heads on top of Dash Top (D).
 - .3 Assemble Steering Column front with Pulley (s), then Front Bearing.
 - .4 Slide Front Bearing into Front Bearing Holder and tighten.
 - .5 Assemble Steering Column rear with Rear Bearing, Steering Wheel flange, and Steering Wheel.
 - .6 Slide Rear Bearing into Rear Bearing Holder and tighten.
- .11 FRONT AXLE YOKE**
- .1 Cut and drill angle iron according to drawing.
 - .2 Trim front end of right piece to fit under left piece where they are joined. (Note: Offset design of yoke is necessary to allow space for turnbuckle.)
 - .3 Bolt yoke to front axle. Use double nuts.

STEERING PULLEYS

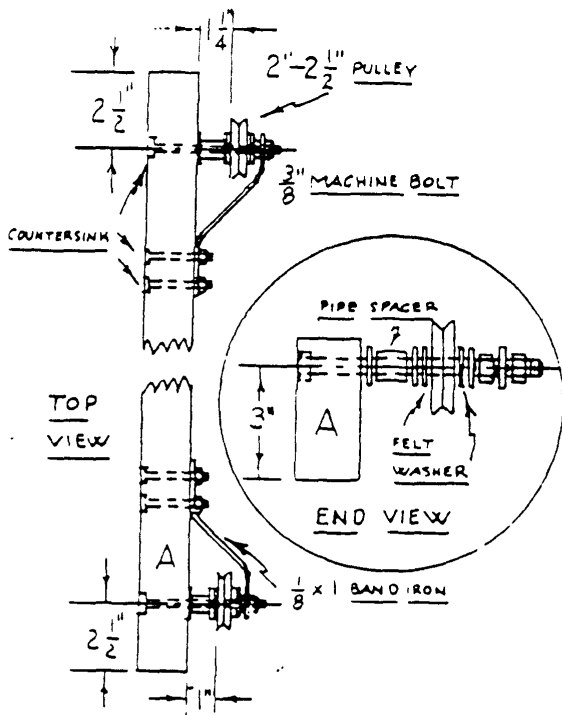

FRONT GRILL

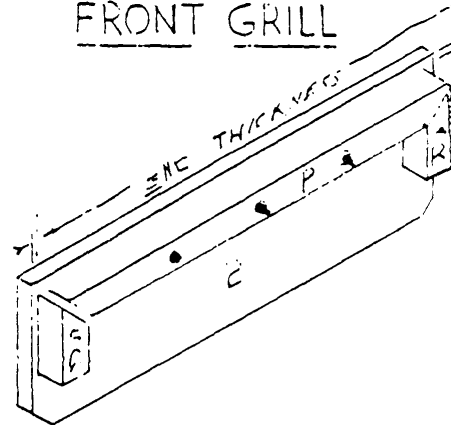

FRONT BRACES

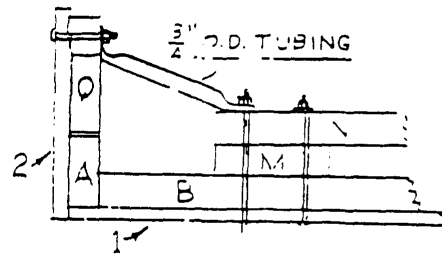

NOTE: PLACE AXLE THROUGH AXLE FRAME (FIG. 7) AND INSERT KING PIN (FIG. 6) BEFORE ATTEMPTING TO ASSEMBLE YOKE.

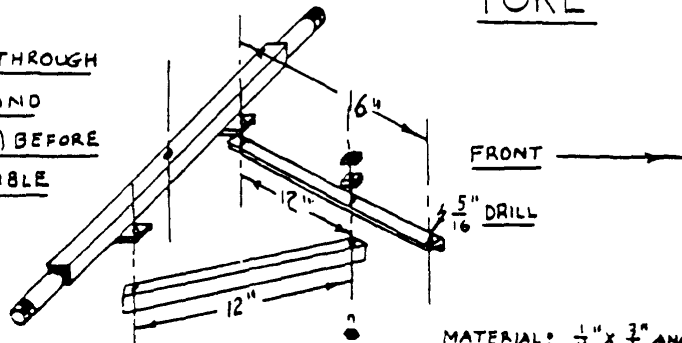

ASSEMBLE WITH 3 - $\frac{1}{4}$ " x 1" STOVE BOLTS
USE DOUBLE NUTS

MATERIAL: $\frac{1}{8}$ " x $\frac{3}{4}$ " ANGLE IRON
LEFT - 17", RIGHT - 13"

Section 4.0 Construction Sequence (con't.)

.12 STEERING CABLE

- .1 Braze turnbuckle eyes closed.
- .2 Make link and drill 5/16" holes 1/2" from each end.
- .3 Assemble turnbuckle and link to front of yoke as shown.
- .4 Insert small cable thimbles in link and turnbuckle ends.
- .5 Clamp end of 3/16" aircraft control cable (or equivalent) to link.
- .6 String cable according to diagram.
- .7 Tighten turnbuckle and use safety wire or locknuts to prevent loosening.

.13 FRONT FENDERS

- .1 Mark and cut both Front Fender (16) pieces to fit over axle slot.
- .2 Plane Dash Top (D) to match slope to top of grill.
- .3 Mark and cut top of Front Fenders (16) to line up between top of Front Grill (2) and Dash Top (D).
- .4 Mark and cut front of Front Fender (16) pieces to miss braces.
- .5 Fasten Front Fender (16) pieces to sides of frame with 1 1/4" flat head wood screws.

.14 AXLE & TIRE ALIGNMENT

- .1 Front and rear axles should be adjusted for 0" camber and 0"- 1/16" toe-in, checked at center of tire at axle level. Adjust by bending at axle bolts.

To Measure: With axles out of the car, scribe a line on each tire. Measure from line to line at front and rear of tires for toe-in, top to bottom for camber. Axle nut must be very tight to get a true reading.

- .2 Install front axle in car, making certain that kingpin is exactly centered, left to right and 17 3/8" from front edge of the Front Bed.
- .3 The rear axle must be 54 1/2" +/- 1" from the front axle (center to center).
- .4 Install rear axle square to car by measuring from center of axle to Rear Cross Frame at the Left Frame and Right Frame. When the measurements are exactly the same, the axle is square to the car.
- .5 Brake drum and chain sprocket should be square to both the rear axle and the motor mounting block. Check drum for high and low spots where sprocket mounts to drum holes. File drum to even out sprocket mounting surface. File half-sprocket at meeting points so run-out can be adjusted before tightening sprocket to brake drum. Square the drive sprocket to the axle. Square the engine mounting block to the axle. Square the engine to the engine mounting block. Once everything is squared and true, chain throwing will almost stop.

.15 REAR AXLE MOUNT

- .1 Rear axle should be bolted to Left and Right Frame with 3/8" bolts. Top of axle tubing may be no higher than flush with Rear Engine Bed.
- .2 No live axles - left rear wheel drive in all cases.

STEERING CABLE

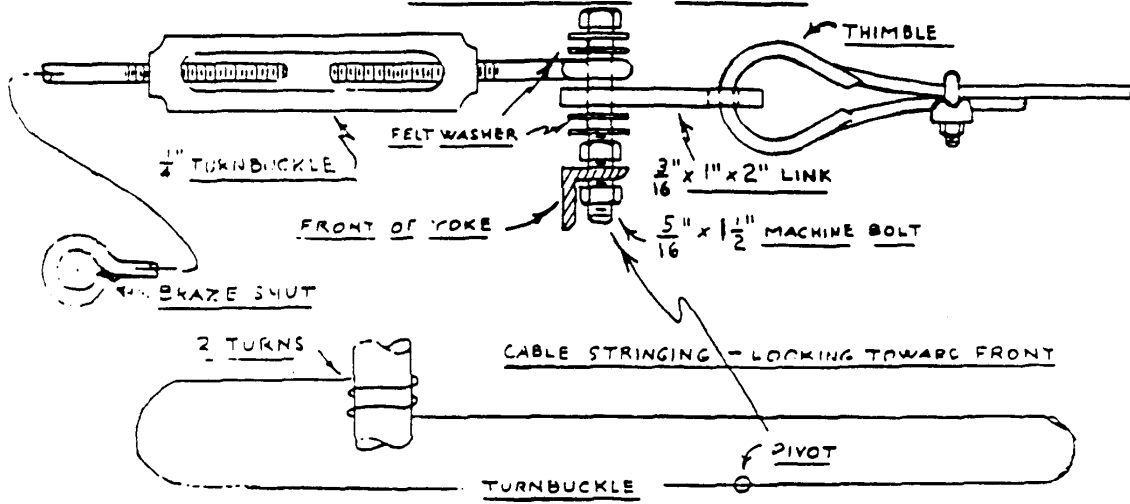

FRONT FENDERS

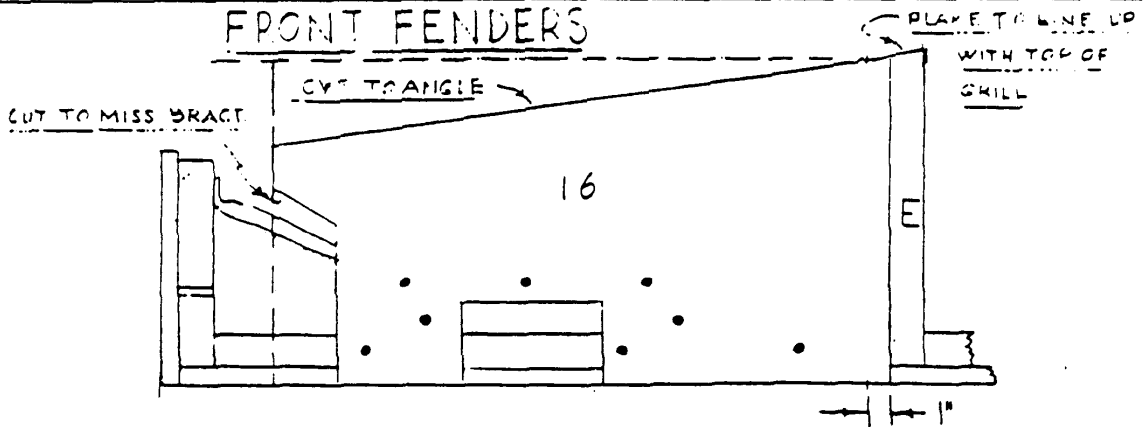

FRONT ENGINE BED

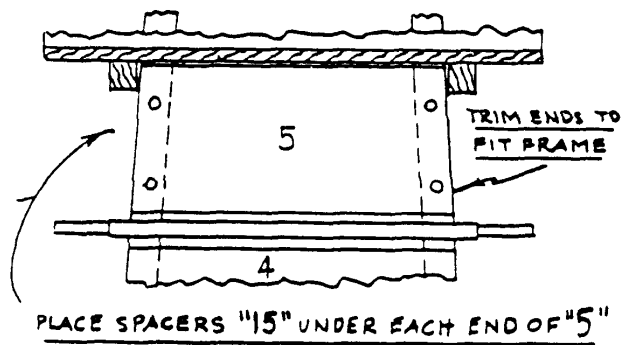

Section 4.0 Construction Sequence (con't.)

.16 FRONT ENGINE BED

- .1 Trim Front Engine Bed (5) to fit frame in front of rear axle.
- .2 Nail Front Engine Bed Spacers (15) on top of Left Frame (B) and Right Frame (C).
- .3 Bolt Front Engine Bed (5) to Left Frame (B) and Right Frame (C).

.17 SEAT

Step 1

- .1 Seat back must bolt to roll cage with a 1/4" bolt.
- .2 Mark width of frame on back of Seat Back (7).
- .3 Place Left Seat Upright (K) and Right Seat Upright (L) on Seat Back (7) outside of marks made in Step 2. Ends of the Seat Uprights should extend 2 1/2" from Seat Back. Countersink heads of bolts and bolt to Seat Back.
- .4 Place Seat Trim (11) on top of Left Seat Upright (K) and Right Seat Upright (L) and fasten with 1 1/2" flat head wood screws. (See inset.)
- .5 Place ends of Left Seat Upright (K) and Right Seat Upright (L) over frame behind Seat Bottom (6). Adjust angle to suit driver and bolt to frame.

Step 2

- .6 Place Seat Bottom (6) on Left Frame (B) and Right Frame (C) with ends lined up with Front Bed (1) and front edge overlapping Front Bed (1) about 1/2". Bolt on. (Countersink heads of bolts flush with surface of Seat Bottom (6).)
- .7 Draw seat angle on Seat Divider (8) and saw to shape. (Round front corner of Seat Divider (8).)
- .8 Bolt Seat Divider Upright (T) and Seat Divider Block (U) on bottom and back edges of Seat Divider. Be sure Seat Divider Upright (T) and Seat Divider Block (U) are on the right side of Seat Divider.
- .9 Bolt Seat Divider into seat slightly to right of center. (Adjust to suit driver.) Right side or center seats are not allowed.

.18 BODY SIDES

- .1 Tip car on side and lay Left Side Piece (20) on car.
- .2 Tack lightly in at least two places and lay out design as in drawing. (Shape of wheel and cockpit cut-outs are optional.)
- .3 Remove side and saw out design.
- .4 Repeat steps for Right Side (21).
- .5 Smooth all edges with plane and sand paper.
- .6 Screw sides to car as shown with 1 1/4" x #9 flat head wood screws. (Countersink all screws.)

SEAT

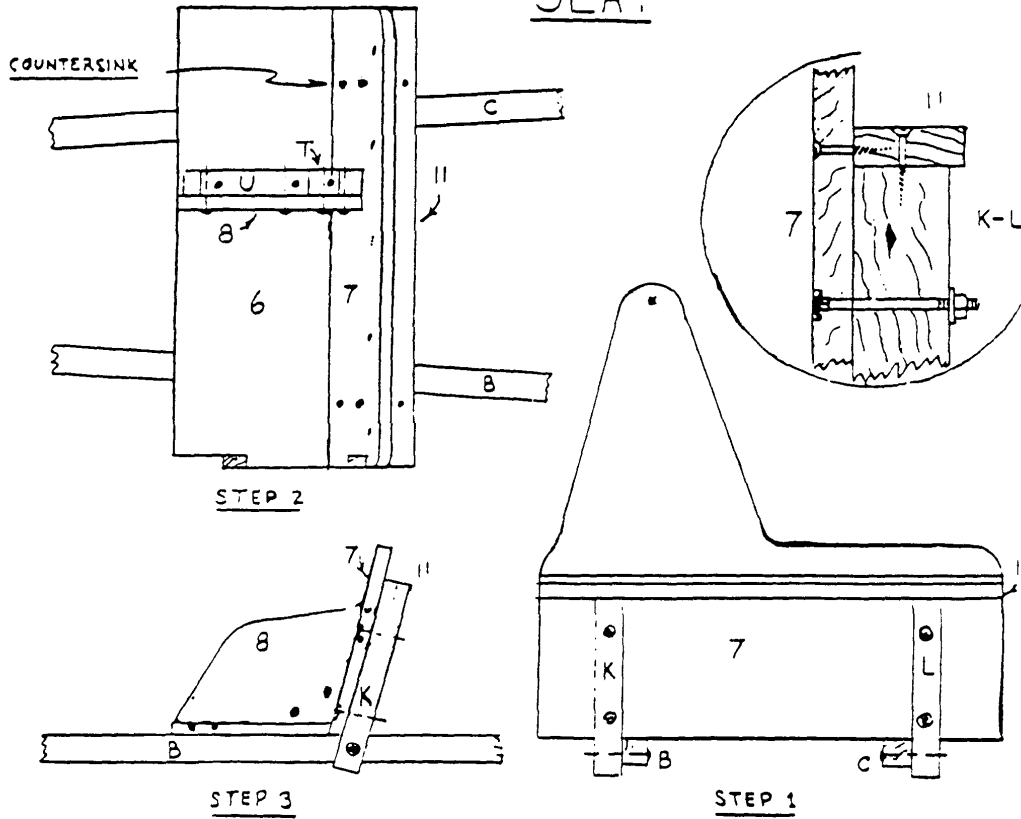

BODY SIDES

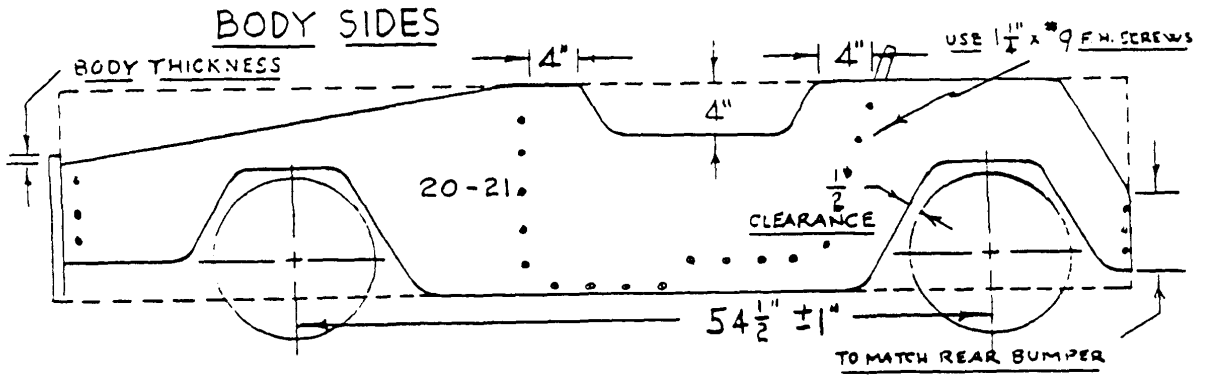

Section 4.0 Construction Sequence (con't.)

.19 HOOD

- .1 Fit Side Hood Anchors (26) to curve of sides as shown.
- .2 Fasten Side Hood Anchors (26) with 1 1/4" - #9 flat head wood screws.
- .3 Place Hood (22), smooth edges and place on car.
- .4 Saw out Hood (22), smooth edges and place on car.
- .5 Drill 8 - 1/4" holes - 2 each edge through hood and Side Hood Anchors (26), Dash Top (D), and Top Grill Support (P).
- .6 Enlarge 8 holes in Side Hood Anchors (26), Dash Top (D) and Top Grill Support (P) to accommodate Wall Anchors with 1/4" bolts.
- .7 Install Wall Anchors in Side Hood Anchors (26), Dash Top (D), and Top Grill Support (P).
- .8 Remove bolts and install Hood.

.20 REAR FENDERS

- .1 A fender over each rear wheel is required. The fender on the drive side should be hinged to Seat Trim (11) and fastened down with a thumb nut. This permits access to drive chain for service.

.21 FRONT BUMPER

- .1 Cut Front Bumper (25) so that exactly 1/4" overlaps each end of Front Grill (2). Round off sharp end corners of Front Bumper (25).
- .2 Bolt Front Bumper (25) to Front Grill (2) as shown. Top must be 10" from the ground. (*NOTE:* End bolts should be slightly above center and arranged to go through Left Grill Support (Q) and Right Grill Support (R).

.22 SCRUB RAILS

(Use birch or maple - pine and plywood not recommended.)

- .1 Cut Left Scrub Rail (23) and Right Scrub Rail (24) to length of car.
- .2 Clamp Scrub Rail to side of car and drill 4 mounting holes. (Holes in car frame are bored 5/16" to facilitate removing rail for tire service.)
 - .1 Front hole through Grill Supports (Q and R).
 - .2 2nd hole through Dash Sides (E and F).
 - .3 3rd hole through roll cage or scrap block behind Seat Back (7).
 - .4 4th hole through scrap blocks in front of rear cross frame.
- .3 Rear wheel well cut out may be replaced to allow painting of full 6" number on car.

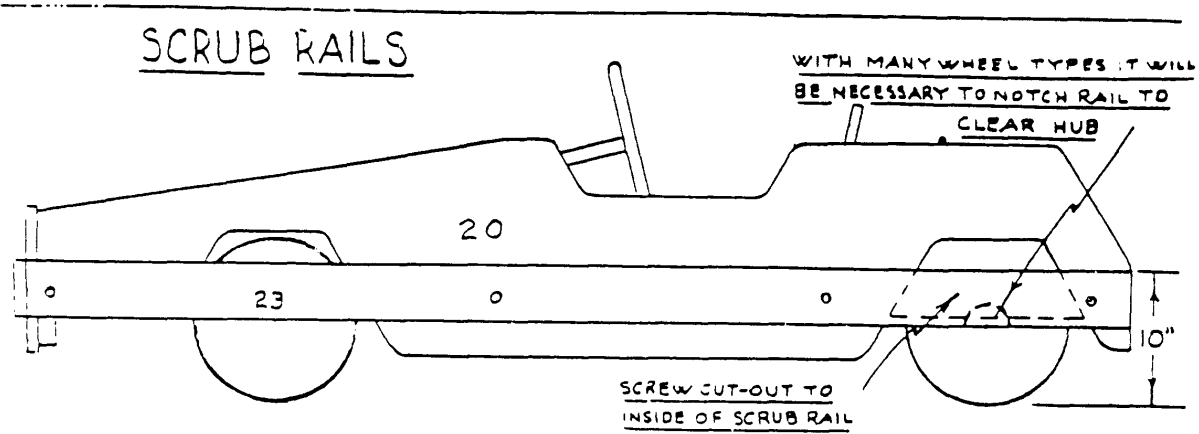
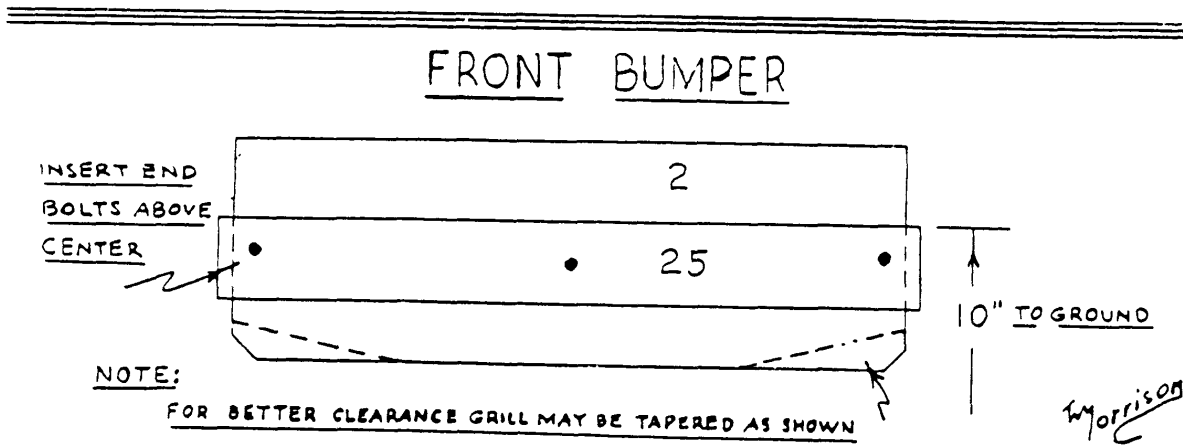
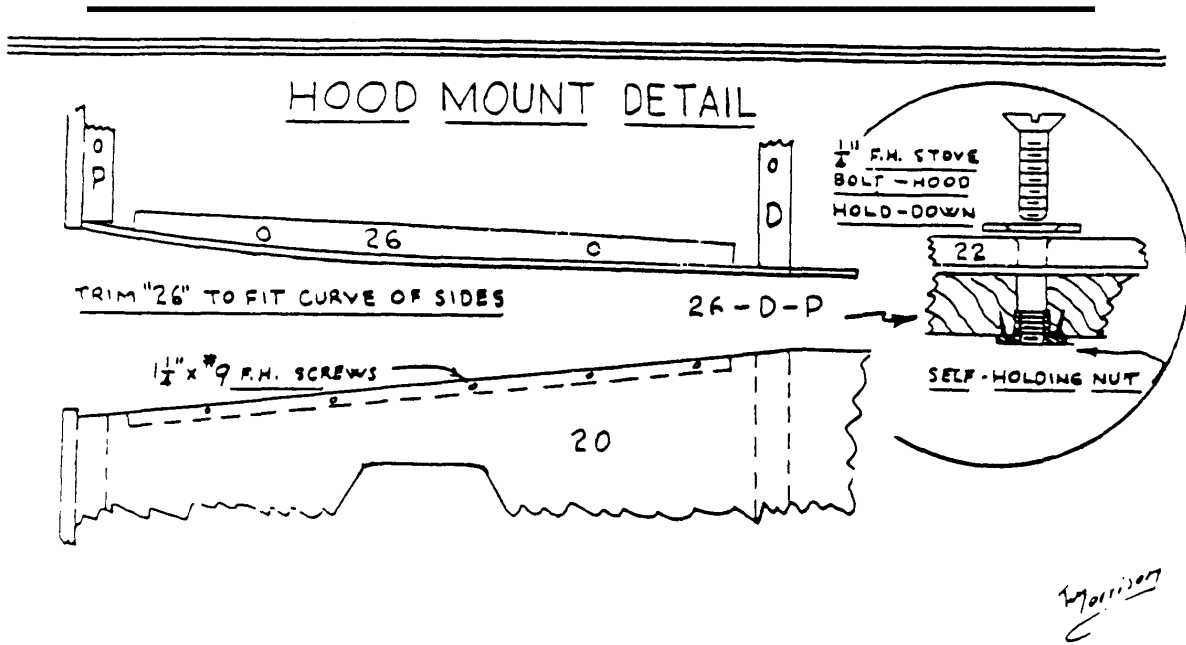

Section 4.0 Construction Sequence (con't.)

.23 ROLL CAGE

- .1 Roll cage material must be round steel tubing with a 3/4" minimum OD and a .050 minimum wall thickness. Thin does not
- .2 Roll cage must run the full length of the cockpit and must start at the floor of the car.
- .3 Uprights and safety bars must be flush with the inside of the car. Roll cage must come in contact with the floor, dash sides and top, and the seat back. There must be a minimum 3" clearance between the driver's helmet and the overhead roll cage bars.
- .4 Roll cage must have overhead safety bars (see #2 on Figure) full length of cockpit, parallel with side of car. When the car lies on it's side these bars measure 8" (+/- 1") from the ground (scrub rail height) , preventing another car from injuring driver from the top in case of a roll over.
- .5 Four additional safety bars (see #3 on Figure) must run parallel with left and right side panels full length of cockpit. One each side directly behind scrub rail, and one each side 3 1/2" (+/- 1/2") higher.
- .6 Front of roll cage can be a maximum of 6" lower than rear of roll cage.
- .7 Seat back must be bolted into the roll cage with 1-1/4" bolt (minimum).
- .8 Roll cage must be of welded construction and may have side-to-side or front-to-rear bends. Bars that are one piece tubing cannot have smaller radius than 6" and should have no kinks.

.24 BRAKES

- .1 Two wheel brakes are mandatory on all cars, all classes. Brakes should be drum or disk type - scrub brakes are no longer allowed for safety reasons. Brakes, when firmly applied by the driver, must be capable of skidding both rear tires. Brakes may be checked weekly.

.25 GAS TANK

- .1 The gas tank is to be located on the rear side of the seat back on the driver upright silhouette. Gas tanks must be of metal construction or racing approved plastic. The tank must be vented. Classes using Club engines must have a fuel filter either in the tank or in the fuel line.

.26 PEDALS

- .1 The design of control pedals are optional to suit driver and builder. The drawing shows one substantial method of mounting pedals.

.27 SWITCH DIAGRAM

- .1 Switch should be placed in cockpit, easily accessible to driver. When running wire to engine, fasten wire securely to bottom of car with insulated clips or staples. Switch is open when engine is running.

.28 SEAT BELTS

- .1 Seat and over-the-shoulder belts for the driver are mandatory. Belts must be tight enough and anchored in such a way that the driver's head cannot hit the steering wheel or the roll cage in the case of a collision or roll-over.

.29 SAFETY NET

- .1 A safety net (nylon or NASCAR webbing type) must be installed to protect the driver's arms and hands during racing or accidents. The safety net will be attached to the front and rear roll cage uprights with quick disconnects; i.e. clothesline hook, swivel snap, round-eye snap, double snap, button snap, etc. Top of safety net shall be no lower than driver's shoulder. The safety net shall be pulled tight to remove slack and the bottom shall be secured so that there are no openings and the driver's arm or hand cannot poke through. The safety net will be positioned on the driver's side.

ROLL CAGE

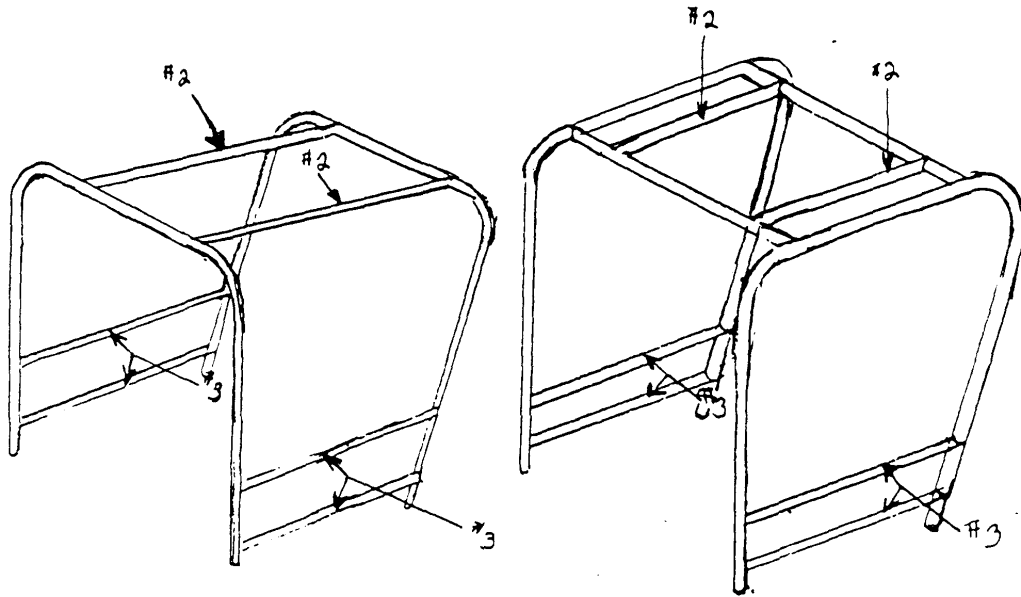

PEDALS

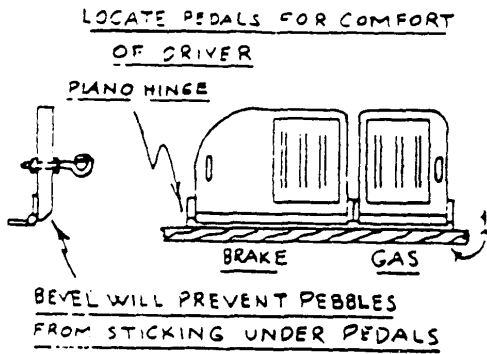

SWITCH DIAGRAM

