

N.Y.S.M.A.

NEW YORK STATE MICROD ASSOCIATION

PRINT DATE: FEBUARY 12, 2000

Chapter 4 - Microd Division Plan Book

Section 1.0 Introduction (Revised 2/00)

In this 13th edition of the NYSMA PLAN BOOK, all technical data, design and safety data has been updated as approved by the NYSMA BOARD OF DIRECTORS through the current race season. This edition contains all current information and supersedes all prior plan book editions, approved proposals, past motions, etc. The changes to the rule book over the years have been changes to better the organization, clarify rules and interpretations and to keep up with changes Manufacturers have done.

Many features of car construction and design, such as brakes, body styles, controls, steering wheel, types of drive, etc. are optional to allow for individual ingenuity. However, all mandatory dimensions, specifications and materials **MUST NOT** be altered.

Additional materials, not listed in this book, may be obtained as needed by referring to the drawings and specifications as building progresses. These materials are not specifically listed because each builder may want to improvise to his or her own ability and resources.



MOST IMPORTANT: DO NOT REDUCE THE MARGIN OF SAFETY. Building a Microd from these plans must be done at the risk of the builder and no responsibility for safety, performance or reliability will be assumed by the New York State Microd Association Incorporated.

Section 2.0 Official Registration Information

.1 Registration

- .1 All Microds must be registered annually with the individual member's club Secretary to qualify for racing events. All fees and correspondence to NYSMA including NYSMA insurance will be directed through the individual member's club Secretary who will forward this information to the elected NYSMA Secretary.

.2 Active NYSMA Clubs

- .1 MID-STATE MICROD CLUB
- .2 SODUS MICROD CLUB
- .3 SOUTHERN TIER MICROD CLUB
- .4 SYRACUSE-GEDDES MICROD ASSOCIATION

.3 Inactive NYSMA Clubs

- .1 CLASSIC MICROD CLUB
- .2 LYONS JR. RACING ASSOCIATION

Section 3.0 Racing Classes

- .1 Class age requirements are as follows:
 - .1 JR. NOVICE**
 - .1 Driver must be at least five (5) years old. The 5th birthday must be on or before May 1st of the racing season year. Or can compete on or after fifth (5th) birthday.
 - .2 Maximum age is 7 years old. Driver must be less than eight (8) years old. The 8th birthday must be after July 15th of the racing season year.
 - .3 Any driver who reaches his eighth (8) birthday before May 1st of the racing season year must move up to the Novice Class.
 - .2 NOVICE**
 - .1 Driver must be at least eight (8) years old. The 8th birthday must be on or before May 1st of the racing season year.
 - .2 Maximum age is eleven (11) years old. Driver must be less than 12 years old. The 12th birthday must be on or after July 15th of the racing season year.
 - .3 The driver may remain in this class for a maximum of three years and two racing seasons.
 - .3 MR-1 LIMITED (This class will be eliminated, modified or combined in the 2001 season)**
 - .1 A new driver must be at least eleven (11) years old. The 11th birthday must be on or before July 15th of the racing season year.
 - .2 Drivers who are nine (9) years old and have raced Novice class previously, can be in this class. The 9th birthday must be on or before July 15th of the racing season year.
 - .3 Drivers who are 10 years old and have raced Novice class previously, can be in this class.
 - .4 Maximum age is thirteen (13) years old. The 14th birthday must be after July 15th of the racing season year.
 - .5 A new or inexperienced driver fourteen (14) years old will have the option of racing for one (1) year only in this class, with the permission of the members individual club Officers and Directors. The 14th birthday must be after July 15th of the racing season year.
 - .4 STOCK**
 - .1 A new driver must be at least twelve (12) years old. The 12th birthday must be on or before July 15th of the racing season year.
 - .2 Drivers who are ten (10) years old and have two years experience, can be in this class. The 10th birthday must be on or before July 15th of the racing season year.
 - .3 Drivers who are ten (10) years old and have raced Novice class previously, can be in this class.
 - .4 Maximum age is fifteen (15) years old. The 16th birthday must be after July 15th of the racing season year.
 - .5 A new or inexperience driver fourteen (16) years old will have the option of racing for one (1) year only in this class, with the permission of the member's individual club Officers and Directors. The 16th birthday must be after July 15th of the racing season year.

Section 3.0 Racing Classes - (continued)

- .5 MR-2 STOCK (6 HP)**
 - .1 Driver must be at least (14) years old. The 14th birthday must be on or before July 15th of the racing season year.
 - .2 Drivers who are 13 years old and have two years of driving experience, have the option to participate in this class. The 13th birthday must be on or before July 15th of the racing season year.
 - .3 Maximum age is seventeen (17) years old. The 18th birthday must be after July 15th of the racing season year.
- .6 SUPER STOCK**
 - .1 Driver must be at least (13) years old. The 13th birthday must be on or before July 15th of the racing season year.
 - .2 Drivers who are 12 years old and have two years of driving experience, have the option to participate in this class. The 12th birthday must be on or before July 15th of the racing season year.
 - .3 Maximum age is seventeen (17) years old. The 18th birthday must be after July 15th of the racing season year.
- .2 A driver must notify the race Director or Club President before they will be allowed to change classes.
- .3 In all classes if a driver participates in one club race for points, the driver cannot drop back to a lower class during the year.

Section 3.0 Racing Classes - (continued)

- .4 For the purpose of the age requirements the ranking order of classes (from lowest to highest)
 - .1 Jr. Novice
 - .2 Novice
 - .3 MR-1 Limited (This class will be eliminated, combined or modified for the 2001 season)
 - .4 Stock
 - .5 MR-2 Stock (6 HP)
 - .6 Super Stock
- .5 Exceptions to the age requirements must be approved by the NYSMA Board of Directors at a regular scheduled meeting prior to March 31st.

Section 4.0 Driver Safety Equipment

.1 Required Equipment

- .1 Approved crash-type safety helmet with secure chin strap.
- .2 Goggles or helmet face shield. (no metal frames)
- .3 Long sleeve shirt or jacket. (sleeves must not ride up)
- .4 Long pants or slacks.
- .5 Shoes or sneakers. (no sandals, togs, etc.)
- .6 Competition type seat belts/harness, 4 point minimum - 5 recommended.
- .7 Safety nets as required.
- .8 Leather or racing type gloves.
- .9 Approved wrist restraints.

.2 Optional Safety Equipment

- .1 Knee and/or elbow pads.
- .2 Padded dash top, roll cage bars, seat and seat back, and other parts within the cockpit area which a driver may contact in the event of a race accident.
- .3 Neck Collars



If the drivers seat is in the center or to the right, an additional net is strongly recommended on the right side of the cockpit opening.

Section 5.0 Microd/Driver Weight by NYSMA Class

.1 Minimum Microd Weight

- .1 All Microds must weigh a minimum of 200 lb. without gasoline or driver.
- .2 To obtain this minimum weight requirement, extra weight should be only as indicated below:
 - .1 Adding non-functional, non-required parts or items solely for the purpose of obtaining the minimum 200 lb., is not allowed. (example - Bolting a piece of metal or weight to the floor or engine bed.)
 - .2 If weight must be added to meet the minimum 200 lb. requirement, such weight must be added in the form of a functional or integral part or component to the required parts of the car. (example- Adding steel tubing to the frame, dash, roll cage, cross members or adding extra support bars or brackets, etc.)

.2 Minimum Combined Car/Driver Weight by Class

- .1 In addition to the minimum car weight of 200 lb., all Microds must meet the following combined Car/Driver weight requirements by NYSMA class below.

NYSMA CLASS	MINIMUM WEIGHT CAR + DRIVER
Junior Novice	300
Novice	320
MR-1 Limited	320
Stock	350
MR-2 Stock	420
Super Stock	420

- .2 The use of bolt in weight (example: lead-pipes, tubing, steel blocks, etc.) in the car must be fastened securely with at least 1 (one) 5/16" nut and bolt combination or 2 (two) 1/4" nut and bolt combination, no nylon ties or tape or mechanics wire will be allowed, all weight must be fastened with a nut and bolt combination described above. This weight requirement will be strictly enforced at all NYSMA sponsored events.

Section 6.0 Wheels & Axles

- .1 Wheels**
 - .1 All wheels must be either 5" or 6" diameter.
 - .2 No tire is to be siped, grooved, or cut in any way, shape or form to aid in traction. The use of rain or dirt tires with grooves from the manufacturer are legal.
- .2 Axles**
 - .1 The minimum axle diameter is 5/8".
 - .2 Material should be steel, aluminum alloy, or other metal of equivalent strength and durability.

Section 7.0 Frame Materials & Parts

.1 Frame Materials

- .1 Frame material for the following frame parts must be one of the following, or any combination of the two.
 - .1 Round Metal Tubing, 1" OD minimum with a 1/16" (.0625" minimum) wall thickness. 7/8" EMT is not allowed.
 - .2 Square Metal Tubing, 1" X 1" minimum as measured across the flat surfaces, or 1 1/4" minimum measured diagonally from corner-to-corner. This tubing must also have a minimum of 1/16" (.0625") wall thickness.

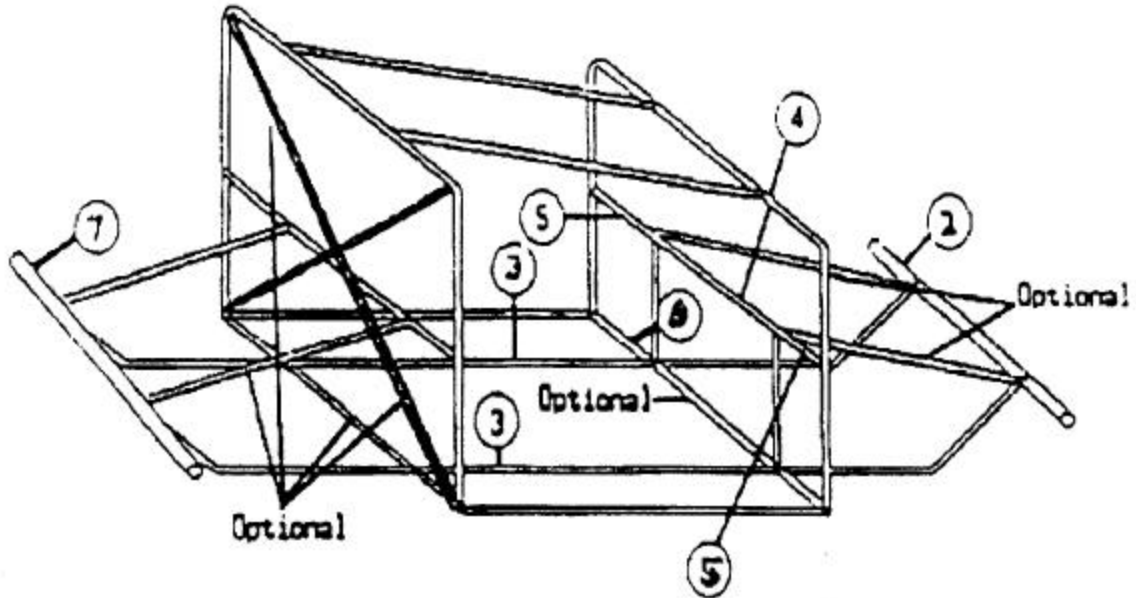

Figure 7.1 - Location of Frame Parts

.2 Front Cross Frame

- .1 Must be a minimum of 32" in width.
- .2 Must come in contact with both the left and right main frame members.

.3 Main Frames - Left and Right

- .1 One solid piece, no minimum length.
- .2 Must run the full length of the Microd from front to rear.
- .3 The main frames must butt up against both the Front Cross Frame and Rear Cross Frame.
- .4 These Main Frames (left and right) can be either straight or contoured, depending upon the individual design of the car.

.4 Dash Top

- .1 Must be 34" minimum width.
- .2 Dash Top parts can be fabricated from more than one piece of frame material.
- .3 If welded as a part of the roll cage, the Dash Top must be made from either 3/4" minimum round EMT conduit or 1" minimum square steel tubing as specified in this section.
- .4 The Dash Top must be a minimum of 13" from the car bottom (inside car) to the bottom of the Dash Top, for at least a 16" minimum width of the Cockpit side-to-side opening. (measured inside)

Section 7.0 Frame Materials & Parts - (continued)

- .5 Dash Sides - Left and Right**
 - .1 Must be at least 11" minimum height from car bottom to the top of the left and right Dash Sides, except when the Dash Top must be 13" minimum height in the cockpit side-to-side opening at the 16" minimum width as specified above.
 - .2 If welded as part of the roll cage, the left and right Dash Sides must be made from 3/4" minimum round EMT conduit or 1" minimum square steel tubing.
- .6 Dash Bottoms - Left and Right**
 - .1 Must be a minimum of 6" in length.
 - .2 In straight frame Microds, Dash Bottoms must go from the Dash Sides to the Left and Right Main Frame Members.
 - .3 In contoured frame Microds, Dash Bottoms are considered to be part of the Left and Right Main Frame Members.
- .7 Rear Cross Frame**
 - .1 Must be a minimum of 35" in length.
 - .2 Must come in contact with both Left and Right Main Frame Members.
 - .3 Should be located between the rear bumper and right and left Main Frame members in such a way to provide maximum protection to the rear of the Microd.
- .8 ALL FRAME PARTS - The above frame parts are required on all Microds. These items may vary dimensionally, but must be in the general position and within the minimum size specified. Adhering to the NYSMA Plan Book dimensions will result in a sturdy and safe car; but those builders who wish to vary from these suggested parts and dimensions must insure that the mandatory parts and dimensions are still met to maintain safety construction standards.**

Section 8.0 Body Parts

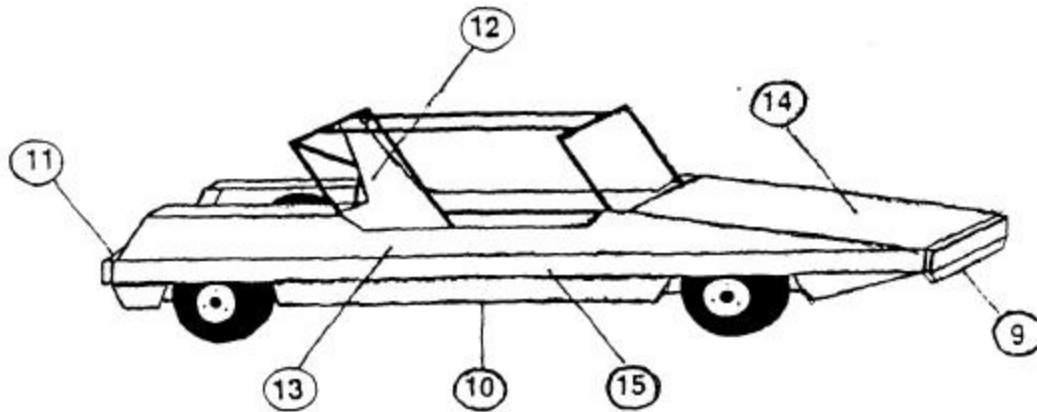

Figure 8.1 - Location of Body Parts

.9 Front Grille

- .1 Minimum length must be at least 32 1/2".
- .2 Height is optional, but the top of the Front Grille must be at least the same height as the top of the left and right Scrub rails.
- .3 Thickness can be either:
 - .1 At least 1/4" minimum to less than 3/4" plywood or 1/8" Polycarbonate if so, then a front Scrub Rail is mandatory.
 - .2 At least 3/4" thick plywood or wood (i.e.. oak, maple, pine, etc.), if so, then a front Scrub Rail is optional.
- .4 Must be solid plywood or wood. Open grille patterns, cutouts, or other openings are not allowed.
- .5 For Microds where the Car Bottom tapers upward toward the front, and the frontal area is the same as the front Scrub Rail, the Front Grille can be considered to be the Front Scrub Rail if it is at least 3/4" thick.
- .6 It must also be positioned perpendicular (at a 90 degree angle) to the ground.

.10 Car Bottom

- .1 Must be minimum 1/2" thick plywood or 1/8" thick aluminum plate only.
- .2 Except for the front wheel openings, it must completely cover the bottom from the front Cross Frame to the Seat Back/Firewall.
- .3 Car Bottom can be one or more pieces of 1/2" plywood or 1/8" aluminum plate. For example, attached to the left and right Main Frame members, as follows:
 - .1 One piece attached on top of the frame for the driver's seat.
 - .2 A second piece attached to the top or bottom of the frame to make up the remaining Car Bottom area.

- e ground to the top edge)
- .3 All Scrub Rails (sides, front and rear) must be perpendicular (90 degree angle) to the ground.

Section 8.0 Body Parts - (continued)

- .4 Must cover the full length of the right and left Body Side Panels of the Microd.
 - .1 The use of segmented scrub rails is allowed for the MR-1 and MR-2 SuperStock classes only.
 - .2 Tires shall not protrude beyond the rail in the lock to lock position. (far left turn-far right turn).
 - .3 All scrub rails must be in place except where the tires extend through the body.
 - .4 Additional bracing must be installed on non-continuous scrub rails to brace the wood at the wheel openings.
 - .5 Extra bolts used to brace and secure the scrub rails must be placed within (2") two inches of the end of the rails at all wheel openings. (see figure)

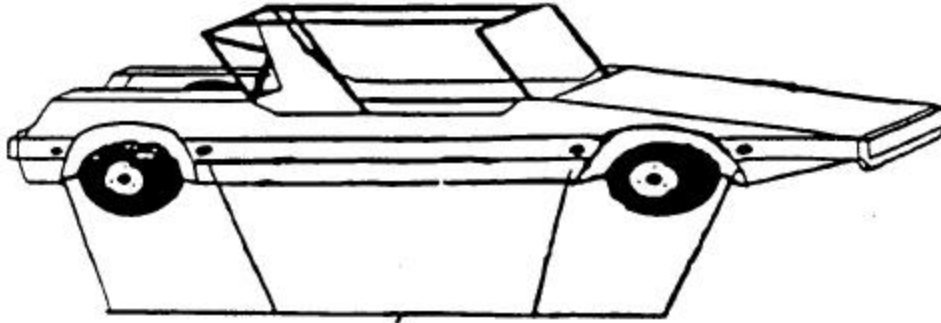

*Figure 8.2 - Location of additional bolts
(within 2" of wheel opening area)*

- .5 Front Scrub Rail can be optional or required, depending upon the thickness of the Front Grille. If the thickness of the Front Grille is less than 3/4" plywood, the Front Scrub Rail is mandatory.
- .6 Left and Right Scrub Rails must be bolted at and to the Front Grille and Rear Bumper (or Front and Rear Cross Members), and have an additional two or more bolts, at least 12" apart, one each in any two of the four following locations, which back-up and solidly support the Left and Right Scrub Rails:
 - .1 left and right Dash Sides
 - .2 Roll Cage horizontal safety bars
 - .3 Roll Cage front or back vertical bars
 - .4 Seat Back/Firewall

Section 9.0 Roll Cage

The Roll Cage is probably the single most important safety item required in the construction of a Microd. extreme care should be exercised when constructing and welding this item. It is recommended that only those experienced in the art of welding should construct their own Roll Cage.

.1 Roll Cage Construction Materials

- .1 The Roll Cage must be constructed of round or square steel tubing or a combination of the two types as follows:
 - .1 Round steel tubing - 3/4" OD minimum x .050" minimum wall thickness. (NOTE: This does not allow the use of 1/2" E.M.T.)
 - .2 Square steel tubing, 3/4" minimum x 3/4" minimum measured across the flat surfaces (or 1" as measured diagonally from corner to corner). This material must also have a minimum .050" wall thickness.
 - .3 Steel Parts must be of only one piece construction. A welded Roll Cage is considered to be one piece construction.
 - .4 NOTE: For increased safety and strength, it is recommended that a minimum 1" round tubing be used to construct all new Microd Roll Cages.

.2 Roll Cage Dimensional Specifications

- .1 The Roll Cage must run the full length of the Cockpit and must be securely anchored to the floor (Car Bottom).
- .2 The Roll Cage uprights and the horizontal safety bars must be no more than a maximum of 4" inside the car when measured from the outside of the scrub rails.
- .3 The Roll Cage must come in contact with the Floor, the Dash (Top or Sides) and the Seat Back/Firewall.
- .4 The Overhead Bar and the Rear Bar must be a minimum of 3" above the Drivers helmet when the driver is seated in the car. When constructing the Roll Cage, it is recommended to allow an additional clearance (3 - 4") to provide for growth of the driver.
- .5 The Roll Cage must have 2 safety bars (#2) on the top (see Figure 9.1) that run the full length of the cockpit opening, parallel with the side of the car, so that when the Microd lies on it's side, these bars measure 8" +/- 1" from the ground, preventing another car from injuring the driver from the top.

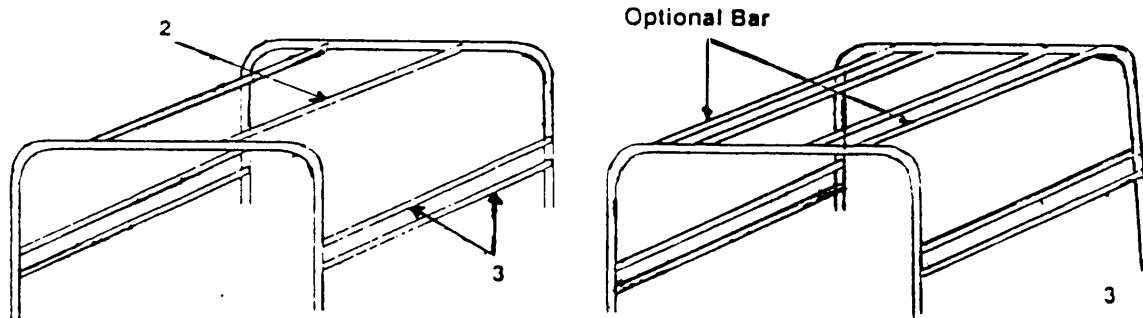

Figure 9.1 - Roll Cage Construction

Section 9.0 Roll Cage - (continued)

- .6 The distance from the top Front Roll Bar to the top rear Roll Bar cannot exceed a maximum of 34" when measured from outside to outside of the roll bars. If this dimension exceeds 34", then an additional top bar is required on the Roll Cage, located in a position to protect the driver's head.
 - .7 For additional safety, two side bars (#3) on each side (see Figure), must run parallel with Left and Right Side Body Panels the full length of the cockpit:
 - .1 two (one on each side) directly inside of and in-line with the Side Scrub Rails, at a height of 8" +/- 1" from the ground.
 - .2 two (one on each side) above the top of the side Scrub Rails (recommended distance approximately 1" to 2" above the top of the Scrub Rails, and no higher than the top of the Dash Top.)
 - .8 Front Roll Cage can be a maximum of 6" lower than the rear bar.
 - .9 Roll Cage must be of welded construction and may be bent side-to-side or from front to rear. Bars that are one piece tubing cannot have a smaller radius than 6" at the bend, and should not have any kinks.
 - .10 The following diagrams are to help illustrate what is required for a strong and safe Roll Cage as determined by the New York State Microd Association.
- .3 Roll Cage - Seat Back / Firewall Support**
- .1 The Seat Back/Firewall must be securely and rigidly fastened to the Roll Cage in a manner that adds side-to-side strength to the Roll Cage while increasing the rigidity of the upper part of the Seat Back driver silhouette. Described below are six options to accomplish this.
 - .1 Option 1 - The top of the driver silhouette extends to the top of the rear cross bar of the Roll Cage and is securely bolted to the Roll Cage using a minimum of 1/4" steel bolt.
 - .2 Option 2 - The top of the driver silhouette is supported by a piece of Roll Cage material welded to the top rear cross bar of the Roll Cage. This brace is fastened to the Seat Back driver silhouette with two 1/4" steel bolts at a minimum of 6" apart. NOTE: The use of flat steel (example 1" x .090") is no longer an acceptable substitute for Roll Cage Material.
 - .3 Option 3 - The driver silhouette is supported by one diagonal reinforcing brace made of Roll Cage Material that is welded at both ends to the Roll Cage upright bars. This brace may be positioned either from the upper left to lower right or from the upper right to the lower left of the Roll Cage. This diagonal brace MUST be positioned so that the upper end is located between points A & B (see figure 9.2), and the lower end is located between points C & D. The Seat Back driver silhouette must then be securely fastened with a minimum of 1/4" steel bolt.

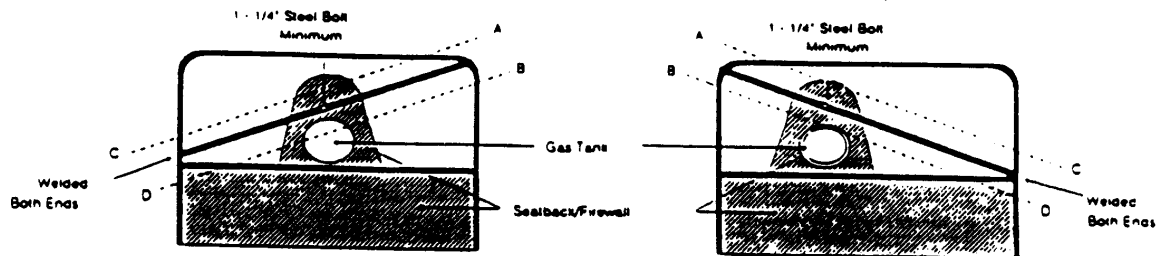

Figure 9.2 - Seat Back/Firewall, Option 3

Section 9.0 Roll Cage - (continued)

- .4 Option 4 - The top or the Seat Back driver silhouette can be supported by two pieces of Roll Cage material welded to the top rear cross bar of the Roll Cage. The ends of these two braces are then attached to the Seat Back driver silhouette with two 1/4" steel bolts; the distance between these two bolts (B) - (the ends of the two braces) must be at least as far apart as the distance between the top of the driver silhouette and the rear top cross bar on the Roll Cage.

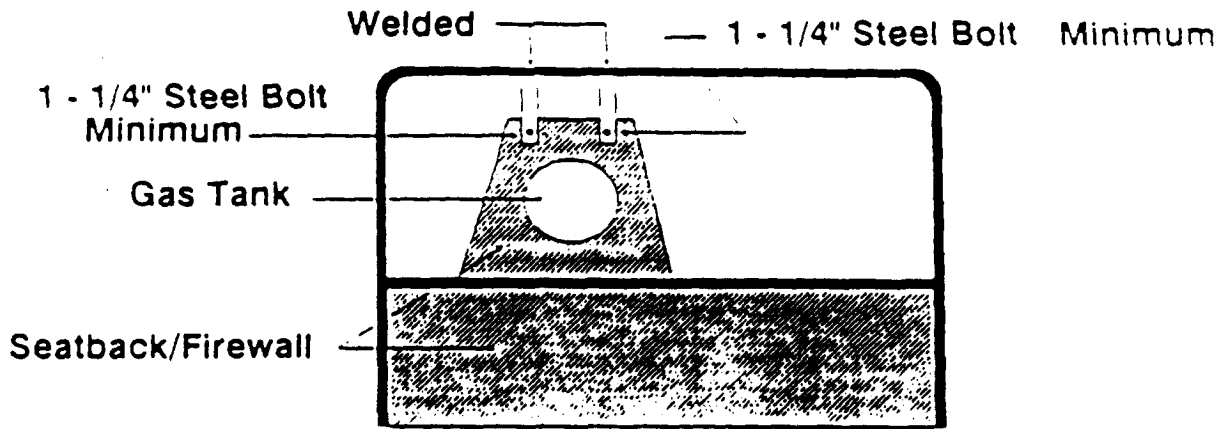

Figure 9.3 - Seat Back/Firewall, Option 4

- .5 Option 5 - Seat Back drivers silhouette to be supported by two (2) pieces of minimum 1/2" E.M.T. .050" thickness metal tubing minimum .050" thick to be welded from point A and B to point C and D from point E and F to point G and H, forming a "triangulated-x" construction thus tying in the upper corners of the roll cage to the lower points of the frame rails.
- .6 Option 6 - Tying the upper corners of the roll cage to the tie bar from cage bar to cage bar bolted to the seat back firewall with the minimum of two (2) 1/4" bolts and a minimum of two (2) inches from each side of the seat back.

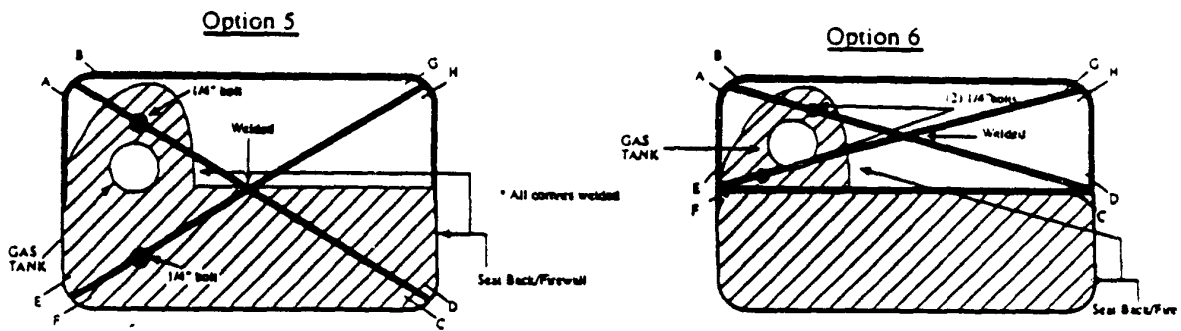

Figure 9.4 - Seat Back/Firewall, Options 5 & 6

Section 9.0 Roll Cage - (continued)

.4 Additional Roll Cage - Seat Back / Firewall Notes

- .1 If any extensions are added to the original Seat Back/Firewall, all measurements and location requirements are measured to the original Seat Back/Firewall, not to the extensions.
- .2 All Microds must be constructed using one of the six Seat Back/Firewall Roll Cage support options as described above and in the four illustrations. Any deviations from these options will be closely inspected by NYSMA inspectors at any NYSMA sponsored events. If the different method is determined to be unsafe, the subject Microd will not be allowed to participate in that race event until acceptable changes are made.

Section 10.0 Dimensions, General Requirements, Compartments, and Guards

.1 Dimensions

- .1 Overall body length must be 84" +/- 2" (minimum 82" to 86" maximum) as measured from outside of the Front Grille to the outside of the Rear Bumper.
- .2 Wheel Base must be 54 1/2" +/- 2" (minimum 52 1/2" to 56 1/2" maximum), when measured from center of the front wheel to the center of the rear wheel on BOTH sides.
- .3 Front width of car measured outside of Scrub Rails must be a minimum of 34" to 40" maximum.
- .4 Rear width of car measured outside of Scrub Rails must be 37" minimum to 40" maximum.
- .5 Scrub Rails must be a minimum of 3/4" thick x 3 1/2" wide and must be mounted at a 90 degree angle to the ground. Scrub Rails must be located so the top of Scrub Rails (and/or Front Grille and Rear Bumper, when front and rear scrub rails are optional) measure 10" +/- 1" from the ground.

.2 General Requirements

- .1 Minimum weight of all Microds, without driver and gas, must be 200 lb..
- .2 All Microd numbers must be located in these areas:
 - .1 On the top of the Hood, a minimum of 6" high.
 - .2 On the left and right Body Side Panels, a minimum of 4" high.
 - .3 On the rear of the gas tank or Seat Back/Firewall, Rear Fenders a minimum of 4" high.
 - .4 All numbers must be of a style and color (with good contrast) and clearly legible for the scorers to read.
 - .5 Any valid unused 1 or 2 digit number may be used. Contact your club for a unused number in your class.
- .3 Decorations, simulated parts, bolts, brackets, or other similar parts that stick out or protrude outside the basic Microd Body and Roll Cage dimensions will not be allowed.
 - .1 Engine gauges, indicators, etc. are allowed as long as they are located inside of the car and present no safety hazard to the driver.

.3 Compartments and Guards

- .1 Front Compartment
 - .1 Front Compartment is defined as the area enclosed by the front Scrub Rail or Front Grill, Body Side Panels, and Hood, back to the Dash Top and Sides.
 - .2 Gas and Brake pedals must be positioned so that when fully depressed and the drivers foot slips off, it does not become caught between the pedals and inner fenders, or cause the pedals to stick.
- .2 **Steering Wheel Column**
 - .1 The Steering Column must be anchored securely enough to prevent the Steering Column and Wheel from being driven toward the rear and into the driver.
 - .2 All Microds must be front wheel steering and rear wheel drive.
 - .3 For bolster, knuckle, rack & pinion or any other type of steering, the following must be used on the steering assembly:
 - .1 double nuts or single self-locking nuts
 - .2 all turnbuckles must be safety wired or safety soldered

Section 10.0 Dimensions, etc. - (continued)

- .3 **Inner Fenders**
 - .1 Inner Fenders, Left and Right are required and must totally enclose and protect the driver's feet.
 - .2 The fenders must allow the driver to easily reach and operate the brake and accelerator pedals while not allowing the feet to become entangled in any other parts of the car or to touch the ground.
 - .3 All inner fenders will be securely mounted using any type of nut or bolt or combination to fasten the inner fenders.
 - .4 Inner fenders may be made of the following materials:
 - .1 1/4" minimum plywood
 - .2 1/8" minimum masonite
 - .3 .015" minimum sheet metal (steel or aluminum)
 - .4 1/8" minimum polycarbonate
- .4 **Front Grille Braces**
 - .1 Front Grill Braces, both Left and Right, must be made of suitable metal material to provide the desired strength and support.
 - .2 Front Grille braces are optional on steel/metal frame Microds, however, their use is recommended if they add additional support and strength to the front end of the Microd.
- .5 **Dash Top Braces**
 - .1 Dash Top Braces, both Left and Right, must be made of suitable metal material to provide the desired strength and support.
 - .2 On cars where the Dash Top is not connected to, or part of the Roll Cage, a minimum of two Dash Top Braces must be installed from the Dash Top to the Left and Right Main Frame members.
- .6 **Other Protrusions**
 - .1 Any other protrusions (i.e.. bolts, brake & gas pedal brackets, pedal holding fixtures, etc.) must be eliminated or padded to prevent injury to the driver.
- .7 **Cockpit Compartment**
 - .1 Cockpit Compartment is the area enclosed by the Dash Top/Sides, Side Body Panels, and Seat Back/Firewall.
 - .2 The Cockpit Opening must be a minimum of 24" front to back as measured from the inside face of the Dash Top to the inside of the 12" minimum height dimension of the Seat Back/Firewall.
 - .3 Minimum Cockpit Opening inside of car measured along the Dash Top must be at least 16".
 - .4 Dash Top height must be a minimum of 13 from car bottom (floor) to the bottom of the Dash Top, for at least the entire 16" minimum width of the Cockpit side-to-side opening.
- .8 **Kill Switch**
 - .1 All Microds must have a Kill Switch which allows the driver to quickly and easily shut off the engine at any time.
 - .2 The Kill Switch must be located to the left or right of the driver, or on the Steering Wheel/Column, but not protruding from the Dash Top.

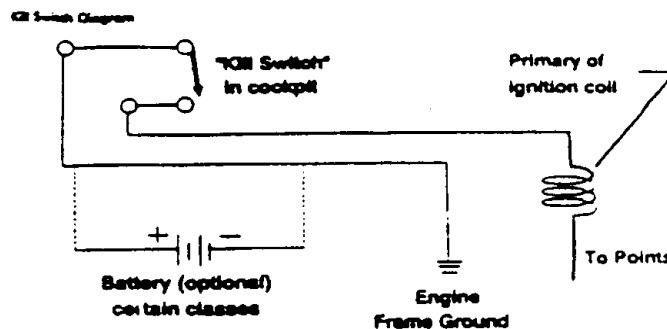

Section 10.0 Dimensions, etc. - (continued)

.9 Safety Net

- .1 A Safety Net (nylon or NASCAR type webbing) must be installed to protect the driver's arms and hands during racing or an accident.
- .2 The Safety Net must be attached to the front and rear Roll Cage uprights with quick disconnects (such as swivel snaps, double snaps, round eye snaps, eye open snaps, button snaps, clothesline type hook, etc.)
- .3 The top of the Safety Net must not be lower than the driver's shoulder, and if possible, should be above the shoulder.
- .4 The Safety Net must be installed tight enough to remove slack, and the bottom of the net must be secured so there are no openings and the driver's hand cannot poke through.
- .5 Microds with the driver positioned to the left or right of center, must have one Safety Net on the side nearest the driver.
- .6 Microds with the driver seated in the center must have at least one Safety Net, side location is optional, however, it is recommended that car builders consider putting Safety Nets on both sides on center driven Microds for maximum safety.

.10 Seat Belts/Harnesses

- .1 The driver must be provided with a seat belt and shoulder harness which:
 - .1 come over the shoulder and are connected to the lap belt, or
 - .2 come over the shoulder, cross the chest, and are connected to the lap belt.
- .2 Belts must be in good condition - not worn or ripped.
- .3 Belts must be securely fastened to the Car Bottom and Seat Back/Firewall
- .4 All belts must have suitable adjustment to hold the driver firmly in the car seat.
- .5 Following are seat belt manufacturer's installation guidelines:
 - .1 Measuring for lap belt:
 - .1 allow a minimum of 3" pull tab on each side.
 - .2 Measure the distance from mounting point to mounting point across the lap and add 6".
 - .3 Compare to the belt length range.
 - .2 Shoulder harness lengths are based on the distance from the adjuster to the mounting point, measured halfway between the collarbone and the chest nipple (approximately underarm level). The shorter the better here. Once installed, take up any slack in the chest harness by the mounting point.
 - .3 Anchor the shoulder harness behind the driver and above a line drawn downward from the shoulder point at an angle of about 40 degrees to the horizontal level with, or no more than 4" below the shoulder line. Never anchor straight down behind the back.
 - .4 Install the crotch strap at an angle parallel to the body line.
 - .5 NOTE: Never use a sternum strap without using a crotch strap.
 - .6 Do not allow any adjustment buckles to ride on the seat. Maintain a minimum of 1 1/2" between the seat and the buckles.
 - .7 Mounting brackets should be installed at the same angle, as the webbing will be pulling under load.

Section 10.0 Dimensions, etc. - (continued)

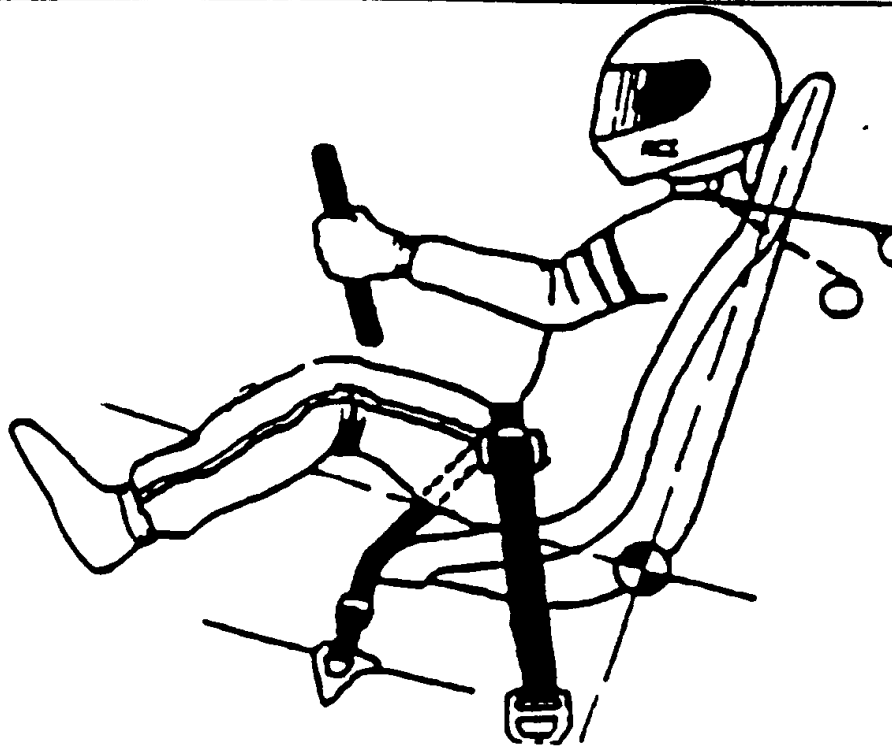

Figure 10.1 - Recommended Seat Belt Mounting

.11 Steering Wheel

- .1 Full round steering wheels are mandatory for cars with cable type steering.
- .2 All other Microds are required to use full round, half round, or Butterfly style Steering Wheels.

.12 Engine Compartment

- .1 The Engine Compartment is the area enclosed by the Seat Back/Firewall and Body Side Panels back to the Rear Bumper.
- .2 It contains the Gas Tank, Engine, Engine Bed, Rear Axle, Brakes, Drive Chain & Sprocket, all overflow containers, Chain Guard, and Rear Fenders.

.13 Gas Tank

- .1 The Gas Tank must be located on the rear axle side of the Seat Back Firewall on the driver upright silhouette, approximately shoulder height - except in classes where the tank is an integral part of the carburetor.
- .2 All Gas Tanks will be mounted to the Seat Back/Firewall free from stress using mounting brackets, bolts, stand offs, etc.
- .3 OEM (original equipment manufacturers) Gas Tanks made of plastic material are not allowed.
- .4 Pressurized Gas Tanks are not allowed.
- .5 All Gas Lines, Overflow lines, and oil overflow lines should be made from approved automotive type fire resistant material.

.14 Rear Wheel Fenders

- .1 The Rear Wheel Fenders, both Left and Right, must extend from the Rear Bumper forward and cover at least the length and width (diameter) of the rear tires.
- .2 All Rear Fenders must be made of the following:
 - .1 Plywood 1/4" minimum or,
 - .2 .030" minimum metal, with no sharp or jagged edges.
 - .3 1/8" minimum polycarbonate.

Section 10.0 Dimensions, etc. - (continued)

.15 Guards - Chain, Clutch and Sprocket

- .1 All Microds must have a minimum of, any style Go-Kart chain guard that covers the chain.
- .2 Microds may also use a guard from the Seat Back/Firewall back to the Rear Bumper or rear of Engine Bed that suitably covers all Chains, Belts, Pulleys, Gears, Sprockets, and Clutch.
- .3 Guards must be a minimum of 2" wide and made from either 1/4" minimum plywood or .030" minimum sheet metal with no sharp or jagged edges or 1/8" polycarbonate.

.16 Flywheel Guard

- .1 All Microd engines must have a flywheel guard that conforms to the following specifications:
 - A. All cut-outs to be the shape of the original engine shroud is acceptable, providing the margin of safety has not been reduced.
 - B. Can be of formed or welded construction, made from 1/8 inch thick minimum steel / iron or 3/16 inch thick minimum aluminum. Minimum width to be no less than 2 inches and mounted
to the existing engine halts.
 - C. In the MR-2 Stock Class a flywheel guard of 3 to 4 inches minimum width is recommended due to the wider and heavier flywheel.

.17 Overflow Containers

- .1 All engines must have an oil overflow with lines that run into an unbreakable container which is securely anchored. These containers must keep all overflows of Engine oil and Gasoline off the racing surface.

Section 11.0 Power Train Requirements

.1 Power Train

- .1 The following are the general requirements and modifications that can be made to the Power/Drive train in all Microd Classes.

.2 Clutch

- .1 All Microds must have a clutch located on the engine Crank/Drive shaft and must be capable of idling the engine at a full stop.
- .2 The Drive Train can be of the direct type (clutch to sprocket) or jack shaft type.

.3 Gear Ratios

- .1 Jr. Novice - 5:1 Max or any ratio numerically lower
- .2 Novice - 6:1 Max or any ratio numerically lower
- .3 MR-1 Limited - Unlimited
- .4 MR-1 Super Stock - 6:1 Max or any ratio numerically lower
- .5 MR-2 Stock - 5:1 Max or any ratio numerically lower
- .6 MR-2 Super Stock - 6:1 Max or any ratio numerically lower

.4 Drive Wheels

- .1 Rear Drive can be left drive, right drive or both driven (live axle).

.5 Brakes

- .1 Brakes must be of design and type that are capable of stopping the Microd if the drive chain or belt breaks.
- .2 All Microds must have a braking system to stop both wheels. If a single wheel drive is used both wheels must stop together.
- .3 The use of two (2) calipers may be used to stop both wheels equally.
- .4 The two most common braking systems used are Hydraulic or Mechanical Disc or Mechanical shoe (drum) brakes.

.6 General Help Section

- .1 Below are some companies that deal in go-kart parts and accessories, a lot of these companies offer parts that are suitable to use on Microds. Here are a few for reference:
 - .1 American Power Sports 1-800-262-0555
 - .2 Comet Kart Sales 1-317-462-2740
 - .3 Competition Karting 1-910-731-6111
 - .4 Fast Track Racing 1-909-654-3610